





# SPECIFICATIONS

MODEL NO  
OBO-50UP1

PART NAME  
SMD-Electromagnetic Transducer

SHEET  
OBO Pro.2 INC.  
2 OF 5

2011 NOV 24

文件发行章

MODEL NO : OBO-50UP1

Features: Drive Circuit Built-In type

Conformity RoHS Directive(2002/95/EC) Requests.

## 1. General Specifications:

Items	Spec.
※1Sound Pressure Level	82 dB min./10cm/DC 5V
Rated Voltage	DC 5V
Resonant Frequency	2700±300 Hz
Rated Current	30mA max./DC 5V
Operating Voltage	DC 4 to 7V
Housing Material	PPS(Black)
Pin Material	Plated Brass(Au)
Operating Temp. Range	-20°C to +70°C
Storage Temp. Range	-30°C to +85°C
Weight	1.5gms
Voltage vs Sound Pressure vs Current Consumption Curve	As Per Fig.1

※ Value applying rated voltage.(DC)

Fig.1:

Measurement distance : 30cm. / Current consumption by GDM-8145

Sound level meter by IEC651 TYPE2 / DC power supply by GPC-3030D

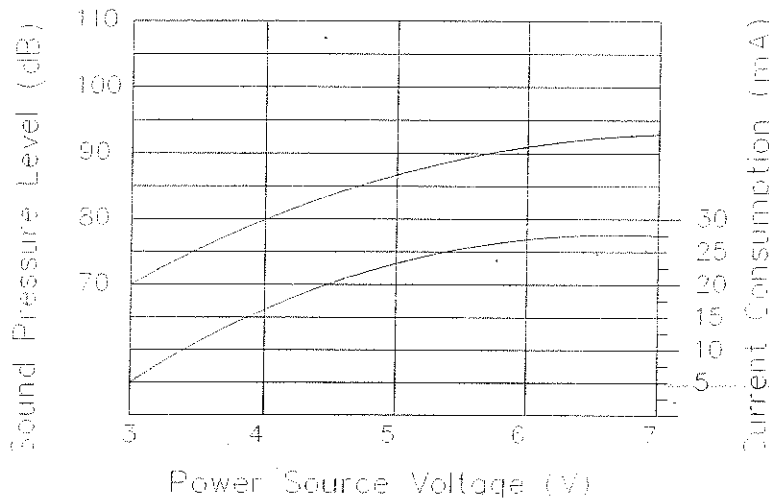

### 2. Standard Test Condition:

#### 2.1 Standard State

Ordinary Temperature	15°C to 35°C
Ordinary Humidity	60% to 70%R.H.
Ordinary air pressure	860 to 1060hPa

#### 2.2 Basic State

Temperature	20±2°C
Humidity	60% to 70%R.H.
Ordinary air pressure	860 to 1060hPa

### 3. Mechanical Layout and Dimensions:

#### 3.1 Dimendions

Tolerance: ±0.3mm Unit: mm

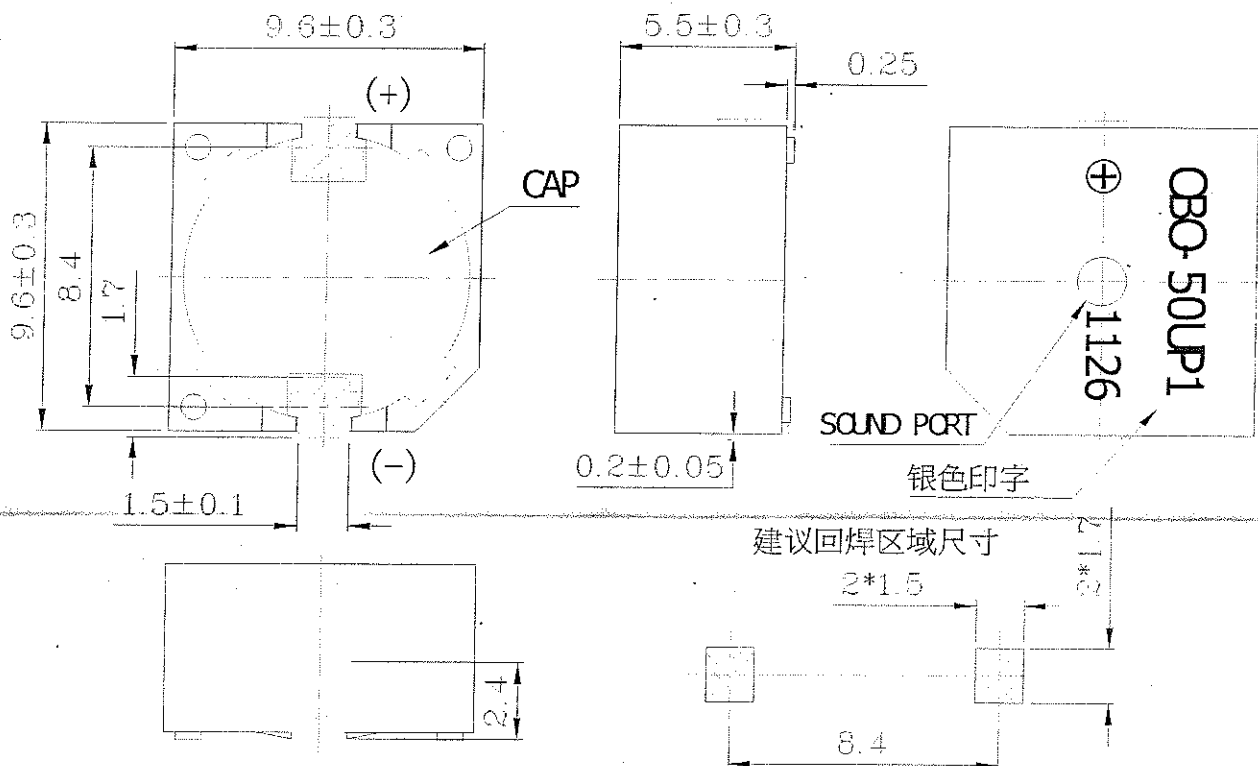

### 4. Soldering Condition:

#### 4.1 Reflow Soldering

Recommendable reflow soldering condition is as follows.

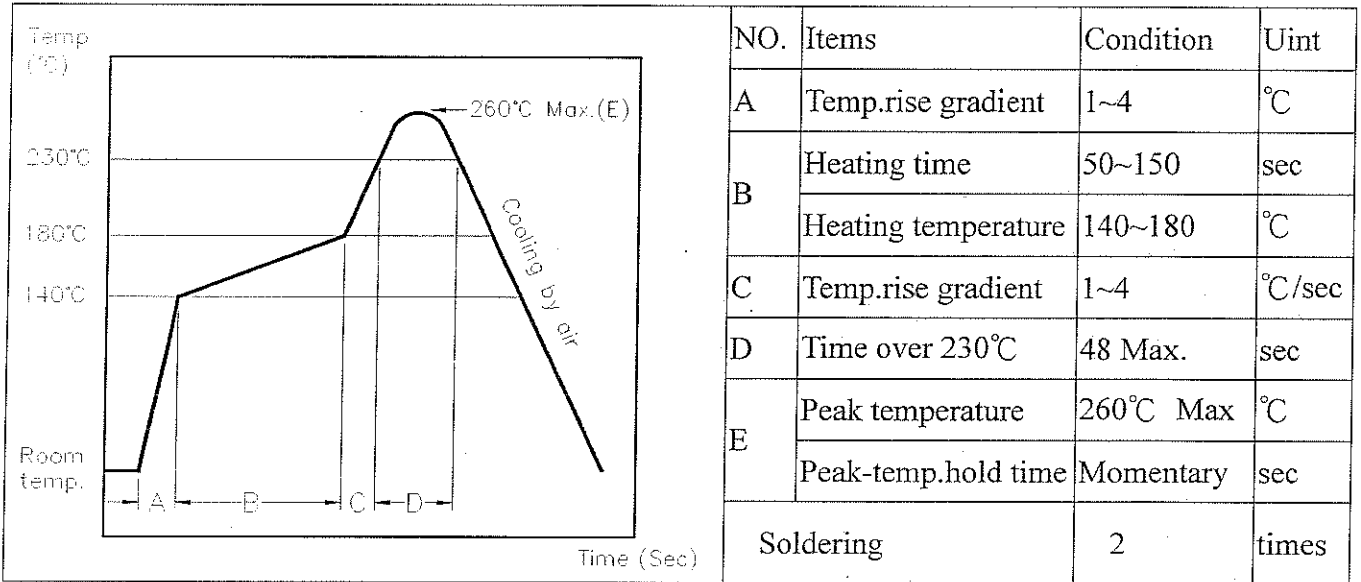

Note :

It is requested that second reflow soldering should be executed after heat of product goes down to normal temperature.

#### 4.2 Hand Soldering

Soldering iron temperature 380°C less than 3 second.

### 5.Packing.

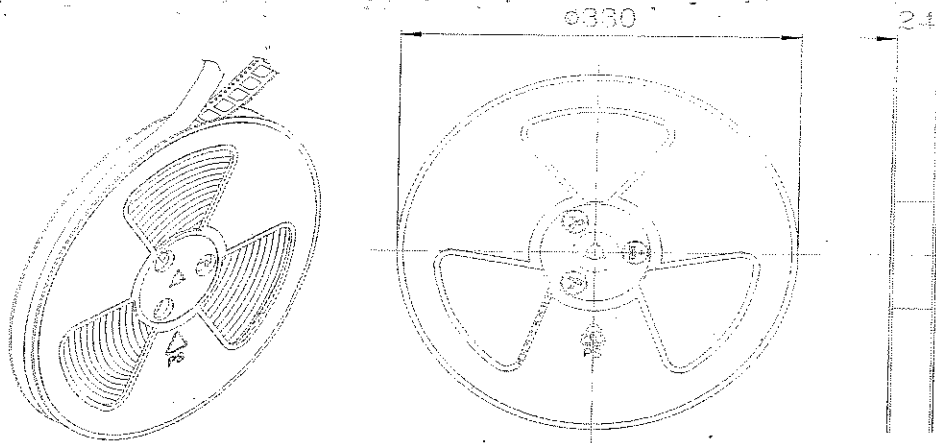

1 Reel : 600PCS

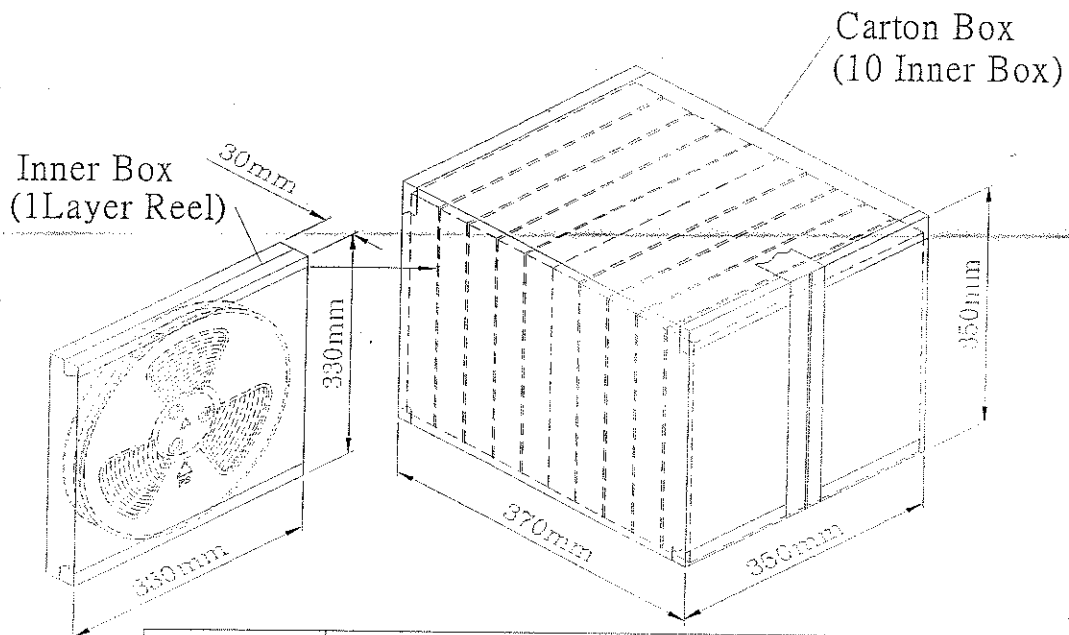
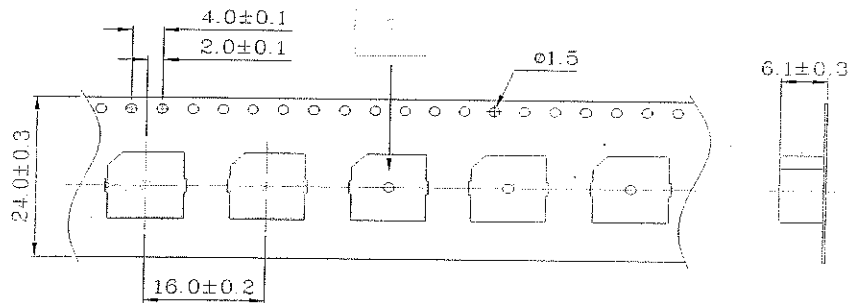

Inner Box	330mmx330mmx30mm	1x600PCS=600PCS
Carton Box	350mmx350mmx370mm	10x600PCS=6,000PCS