



<b>OBO® Pro.2®</b>	<b>SPECIFICATIONS</b>	<b>MODEL NO.</b> OBO-27220
	<b>PART NAME</b> Piezoelectric Buzzer	<b>SHEET</b> 2 OF 5

Model No. : OBO-27220

Features : Conformity RoHS Directive ( 2002/95/EC ) Requests. ※2

### 1. General Requirements

Items	Spec.
Sound Pressure Level	85dB Min. at 3.5KHz/9Vp-p Square Wave/10cm.
	75dB Min. at 3.5KHz/1Vrms Sine Wave/10cm.
Capacitance	24,000pF ± 30% at 120Hz
Current Consumption	4mA Max. at 3.5KHz/9Vp-p Square Wave
Allowable Input Voltage	30Vp-p Max.
Case Material	ABS (UL 94HB)
Operating Temp. Range	-20°C to +60°C
Storage Temp. Range	-30°C to +70°C
Weight	4.3gms
Frequency Response	As Per Fig.1

### 2. Test Method

#### 2.1 Standard Test Diagram

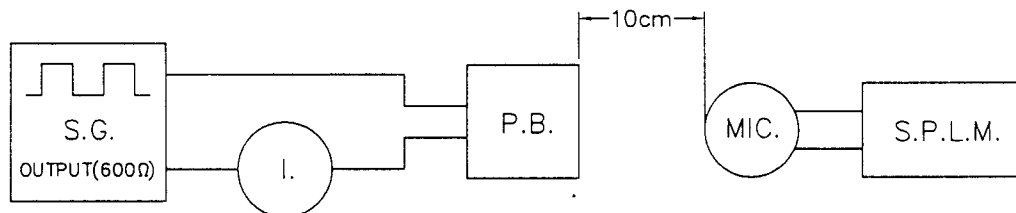

- S.G. : GAG-808G Audio Ggenerator or Equivalent
- S.P.L.M. : Sound Pressure Level Meter IEC651 TYPE2
- I. : GDM-8145 Multimeter or Equivalent
- P.B. : Piezoelectric Buzzer

Note: Please pay attention never to be applied DC voltage to piezo sounder

<b>OBO Pro.2</b> ®	<b>SPECIFICATIONS</b>	<b>MODEL NO.</b> OBO-27220
	<b>PART NAME</b> Piezoelectric Buzzer	<b>SHEET</b> 3 OF 5

### 3. Appearance and Dimensions

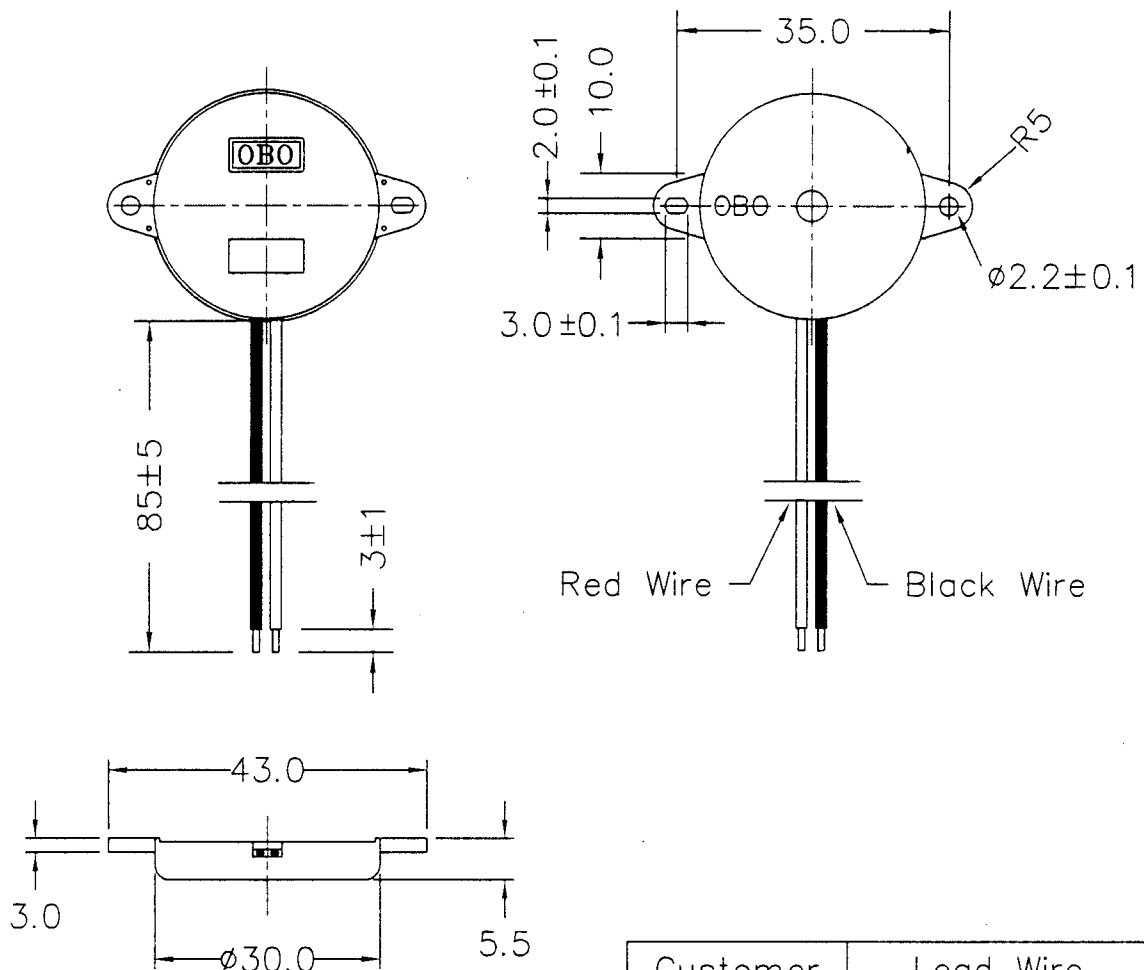

Red Wire  
Black Wire

Unit : mm      Tolerance :  $\pm 0.5$

Customer	Lead Wire
Standard	UL1095#28

### 4. Environment-related substances to be controlled

- Piezoelectric Ceramic Disc.

※2

RoHs Annex :

Application of lead, mercury, cadmium and hexavalent chromium, which are exempted from the requirement of article 4(1).

\* Lead in electronic ceramic parts.(e.g. piezoelectronic devices).

<b>OBO Pro.2</b> <sup>®</sup>	<b>SPECIFICATIONS</b>	<b>MODEL NO.</b> OBO-27220
	PART NAME Piezoelectric Buzzer	<b>SHEET</b> 4 OF 5

5. Soldering condition

5.1 Hand soldering

Soldering iron tip temperature 380C°Max for 3 seconds.

6. Package

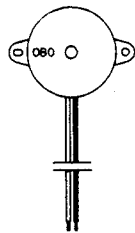

Buzzer

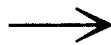

**OBO PRO.2 INC.**

MODEL NO.	
LOT NO.	
QUANTITY	
DATE	

50pcs / Label  
(80\*50\*0.08mm)



50pcs/ PE Bag  
(220\*155\*0.05mm)

RoHS Tape



※2

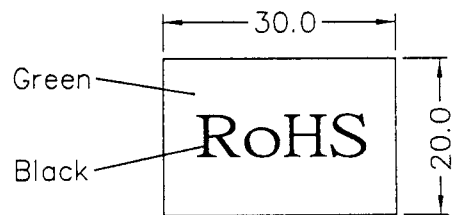

RoHS Tape  
(30\*20 mm)

RoHS Tape

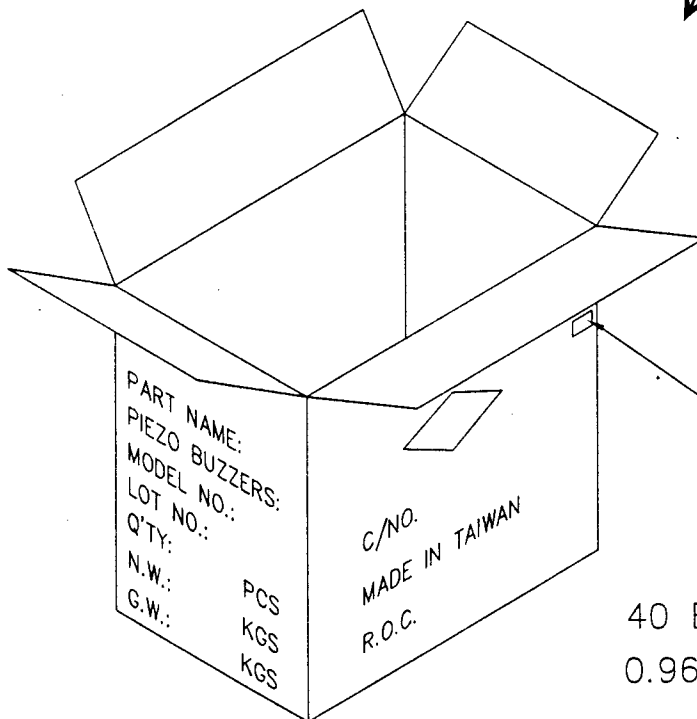

40 Bag(2000pcs)/ Carton  
0.96寸(352\*233\*336mm)

Fig. 1: Frequency Response, Magn dB re 20.00µpa

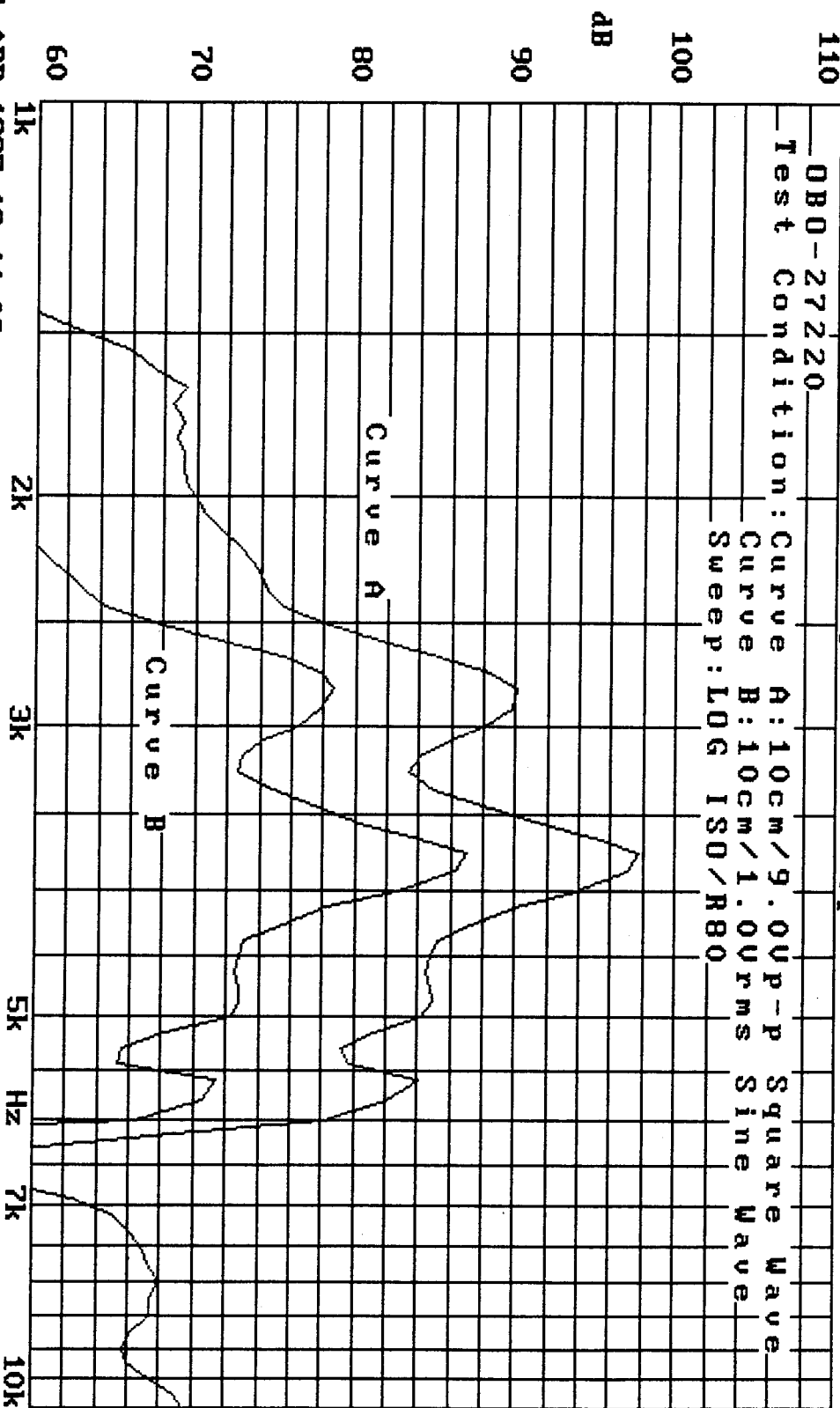

21-APR-1997 18:44:08

Mode: SSR

