

OBO Pro.2	SPECIFICATIONS	MODEL NO. OBO-40BS3
	PART NAME SMD-Electromagnetic Transducer	SHEET 1 OF 8

ALTERNATION HISTORY

Marking	Date	ECN NO.	REV.	Description	Page	PREPARE BY	APPROVE BY
※1	MAY,16'06	0605003	C	Conformity RoHS Directive (2002/95/EC) Requests.	8	馮仁如	葉可強 ⁰⁶

REV.	DATE	PREPARED BY	CHECKED BY	APPROVED BY
C	MAY,16,2006	LULU	葉可強 ⁰⁶	葉可強 ⁰⁶

OBO Pro.2	SPECIFICATIONS	MODEL NO. OBO-40BS3
	PART NAME SMD-Electromagnetic Transducer	SHEET 2 OF 8

MODEL NO : OBO-40BS3

Features : Conformity RoHS Directive (2002/95/EC) Requests. ※1

1、General Specifications :

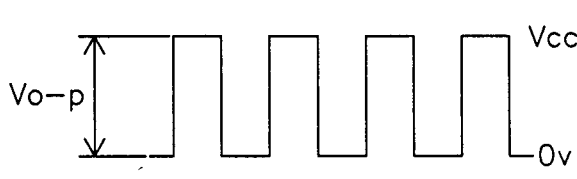
	Items	Specification	Conditions
1.1	Rated Voltage	5.0 Vo-p	 <p>Squarewave 1/2 Duty</p>
1.2	Operating Voltage	4-6 Vo-p	
1.3	Resonant Frequency	2730Hz	
1.4	Sound Pressure Level	85dB min.	Standard State, Standard Drive circuit, Rated Voltage, Distance at 0.1m(A-weight) 2730Hz Squarewave 1/2 Duty.
1.5	Average Current Consumption	80mA max.	
1.6	Coil Resistance	30±5Ω	
1.7	Operating Temp. Range	-30°C~+70°C	SPL ≥ 80dB at "1.4"
1.8	Storage Temp. Range	-40°C~+85°C	
1.9	Housing Material	LCP	
1.10	Weight	1.0g	

OBO Pro.2	SPECIFICATIONS	MODEL NO. OBO-40BS3
	PART NAME SMD-Electromagnetic Transducer	SHEET 3 OF 8

2 · Mechanical Layout and Dimensions :

2.1 Dimensions

Tolerance: ±0.2mm Unit: mm

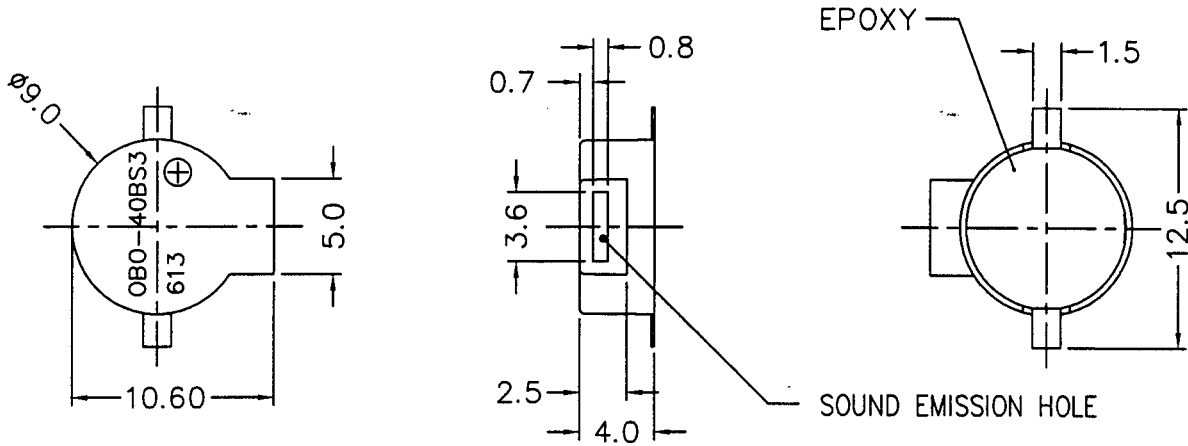

Note :

Meaning of Stamp Mark

613 : Production Lot No.

6 : Year 2006 (last 1 figures of the year)

13 : week (01~55)

OBO-40BS3 : Model No.

⊕ : Polarity identification mark

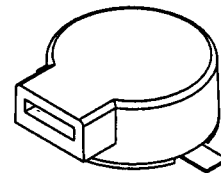

3 · Standard test Conditions :

3.1 Standard State

Ordinary Temperature	15°C to 35°C
Ordinary Humidity	25% to 85%
Ordinary air pressure	860 to 1060hPa

In case of doubtful judgment, the test is re-performed under Basic State.

3.2 Basic State

Temperature	20±2°C
Humidity	60% to 70%
Ordinary air pressure	860 to 1060hPa

OBO Pro.2	SPECIFICATIONS	MODEL NO. OBO-40BS3
	PART NAME SMD-Electromagnetic Transducer	SHEET 4 OF 8

4、Test method :

4.1 Standard Drive Circuit

Signal amplitude should be large enough to saturate the transistor which drives the buzzer.

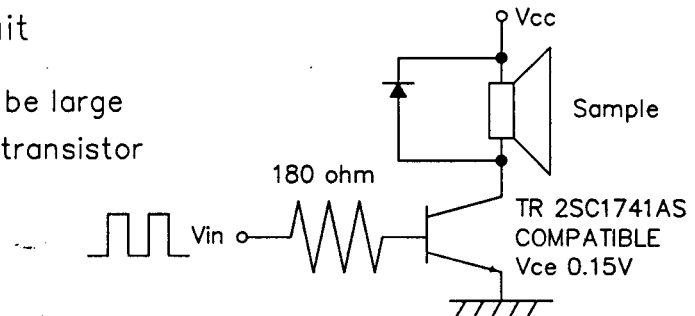

4.2 Standard Test Fixture

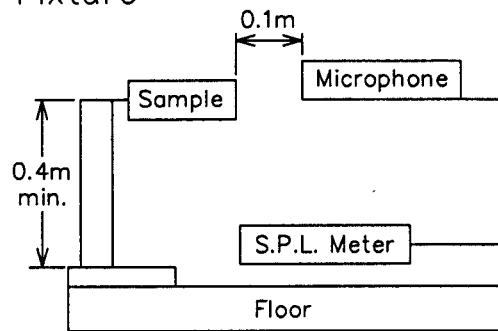

5、Soldering Condition :

5.1 Reflow Soldering ※1

Recommendable reflow soldering condition is as follows.

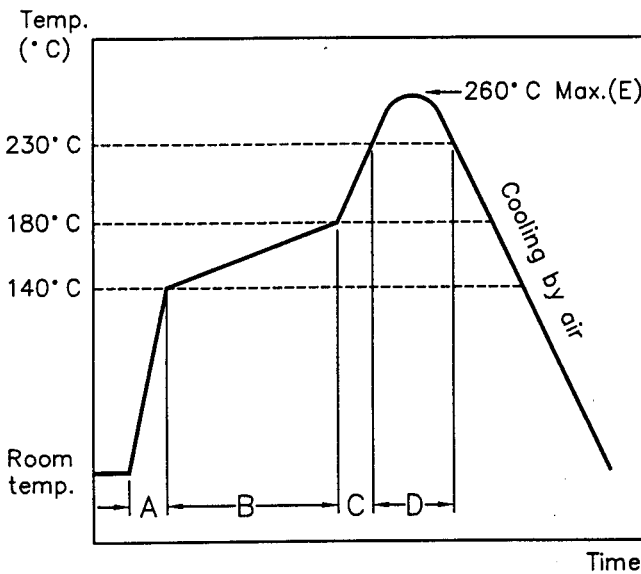

NO.	Items	Condition	Unit
A	Temp. rise gradient	1 ~ 4	°C/sec
B	Heating time	50~150	sec
	Heating temperature	140~180	°C
C	Temp. rise gradient	1 ~ 4	°C/sec
D	Time over 230°C	48 Max.	sec
E	Peak temperature	260°C Max.	°C
	Peak-temp. hold time	Momentary	sec
Soldering		2	times

Note :

it is requested that second reflow soldering should be executed after heat of product goes down to normal temperature.

5.2 Hand Soldering ※1

Soldering iron temperature 380°C less than 3 second.

OBO Pro.2	SPECIFICATIONS	MODEL NO. OBO-40BS3
	PART NAME SMD-Electromagnetic Transducer	SHEET 5 OF 8

6、Reliability test :

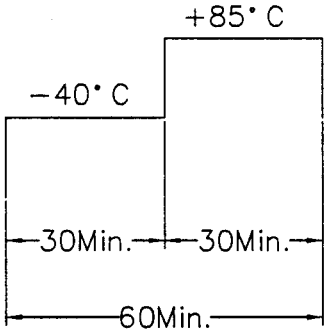
NO.	Items	Test Conditions	Evaluation Criteria
6.1	※1 High Temp. Storage	The part shall be capable of withstanding a storage temperature of +85°C for 240 hours.	After the test the part shall meet specifications without any degradation in appearance and performance except SPL. SPL shall be 80dB or more.
6.2	※1 Low Temp. Storage	The part shall be capable of withstanding a storage temperature of -40°C for 240 hours.	
6.3	Thermal Shock	The part shall be subjected to 50 cycle. One cycle shall consist of : transfer time : 10 minutes 	
6.4	※1 Humidity Test	The part shall be subjected to +60°C, 90% RH for 240 hours, and expose to room temperature for 6 hours.	
6.5	Vibration	10 - 55 - 10Hz, Sinewave Sweep 15 min. X,Y,Z 3 Direction 2 hours each, Total 6 hours.	
6.6	Drop test	Drop on hard wood board of 5cm. thick, any direction, 10 times, at the height of 100cm	

OBO Pro.2	SPECIFICATIONS	MODEL NO. OBO-40BS3
	PART NAME SMD-Electromagnetic Transducer	SHEET 6 OF 8

NO.	Items	Test Conditions	Evaluation Criteria
6.7	Ordinary Temp. life ※1	The part shall be subjected to 240 hours at 25±10°C. Input 5.0Vp-p Squarewave 1/2duty 2730Hz	
6.8	High Temp. life ※1	The part shall be subjected to 240 hours at +85°C. Input 5.0Vp-p Squarewave 1/2duty 2730Hz	
6.9	Low Temp. life ※1	The part shall be subjected to 240 hours at -30°C. Input 5.0Vp-p Squarewave 1/2duty 2730Hz	
6.10	Reflow ※1		<p>a. No abnormality should be found after the test</p> <p>b. Good soldering to meet soldering requirements</p>

Notes :

As this product is not protected from foreign material entering, please make sure that that any foreign materials (e.g. magnetic powder, washing solvent, flux, corrosive gas) do not enter this product in your production processes. The functional degradation (e.g. SPL down) may occur if foreign material enter it.

	<p>SPECIFICATIONS</p>	<p>MODEL NO. OBO-40BS3</p>
	<p>PART NAME SMD-Electromagnetic Transducer</p>	<p>SHEET 7 OF 8</p>

7、 Packing Information :

Unit : m.m.

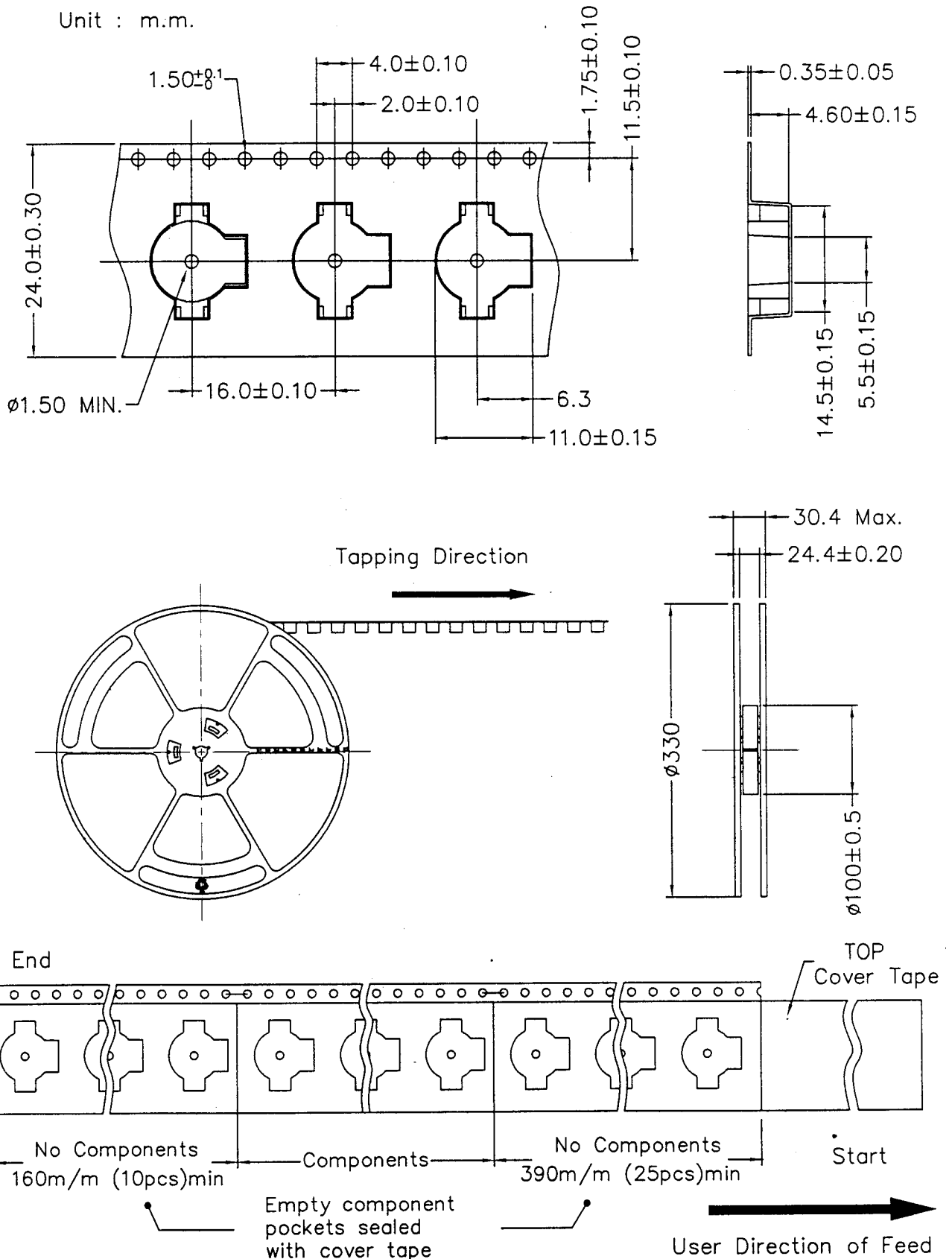

OBO Pro.2	SPECIFICATIONS	MODEL NO. OBO-40BS3
	PART NAME SMD-Electromagnetic Transducer	SHEET 8 OF 8

Label content

OBO Acoustic Components OBO PRO.2 INC.	
Model No.	OBO-40BS3
Production Order	*****
Lot NO.	***
Q'TY	900 pcs
Date	*****

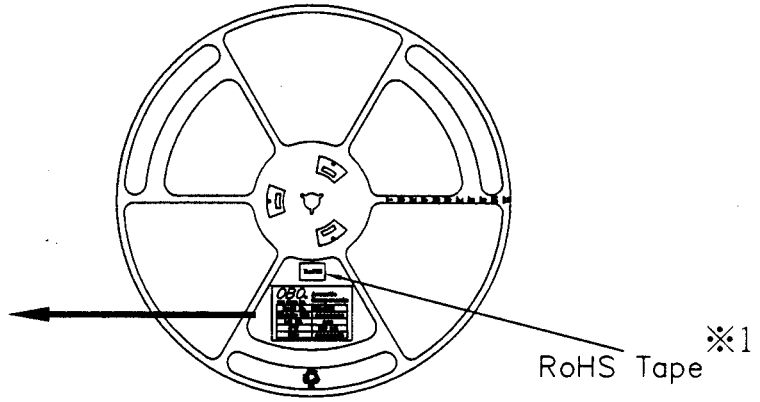

Inside box

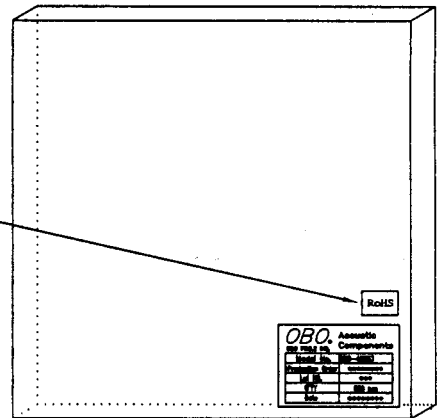

1 Reel / Inside box
(33.6*3.8*34.2)

RoHS Tape ※1

Carton

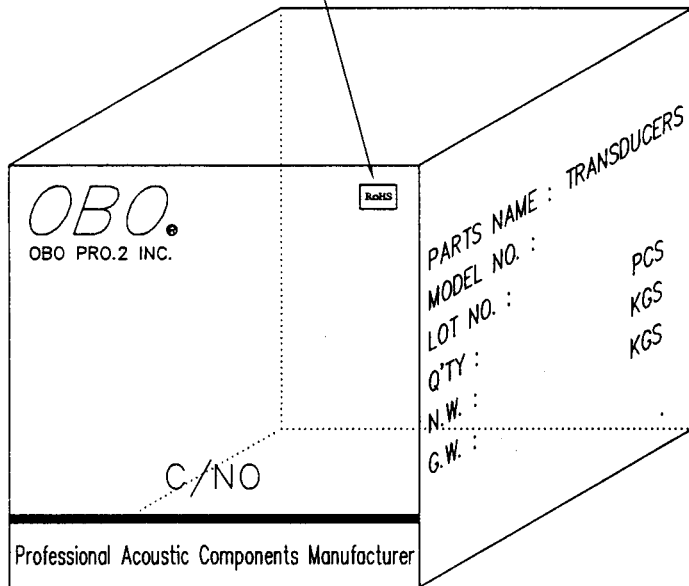

10 Inside box (9000pcs)
/ Carton (34.8*40.0*36.0)

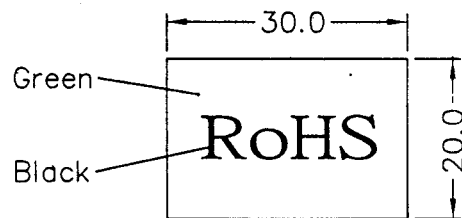

RoHS Tape ※1
(30*20 mm)