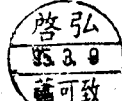

OBO Pro.2	SPECIFICATIONS	MODEL NO. OBO-152
	PART NAME Piezoelectric Buzzer	SHEET 1 OF 5

ALTERNATION HISTORY

Marking	Date	ECN. NO.	REV.	Description	Page	PREPARE BY	APPROVE BY
※1	JAN.05'06	0512024	H	Conformity RoHS Directive (2002/95/EC) Requests.	5	簡沛玲	

REV.	DATE	PREPARED BY	CHECKED BY	APPROVED BY
H	JAN,05,2006	PEI LING	馮仁如	

OBO Pro.2	SPECIFICATIONS	MODEL NO. OBO-152
	PART NAME Piezoelectric Buzzer	SHEET 2 OF 5

MODEL NO : OBO-152

**Features : External Drive And Conformity RoHS Directive
(2002/95/EC) Requests. ※1**

1. General Specifications :

	Items	Spec.
1.1	Sound Pressure Level	80dB min. at 4.0KHz/9Vp-p Square Wave/10cm
		70dB min. at 4.0KHz/1Vrms Sine Wave/10cm
1.2	Capacitance	14,000pF ± 30% at 120Hz
1.3	Current Consumption	3mA max. at 40KHz/9Vp-p Square Wave
1.4	Allowable Input Voltage	30Vp-p max.
1.5	Case Material	ABS (UL 94HB)
1.6	Operating Temp. Range	-20°C to +60°C
1.7	Storage Temp. Range	-30°C to +70°C
1.8	Weight	0.9 gms

2. Test Method : ※1

2.1 Standard Test Diagram

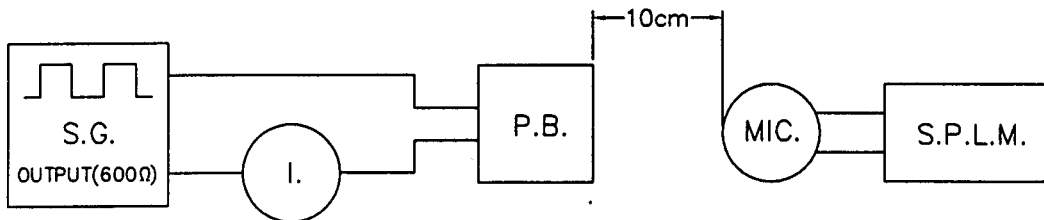

- S.G. : GAG-808G Audio Ggenerator or Equivalent
- S.P.L.M. : Sound Pressure Level Meter IEC651 TYPE2
- I. : GDM-8145 Multimeter or Equivalent
- P.B. : Piezoelectric Buzzer

Note: please pay attention never to be applied DC voltageto piezo sounder

OBO Pro.2	SPECIFICATIONS	MODEL NO. OBO-152
	PART NAME Piezoelectric Buzzer	SHEET 3 OF 5

3. Dimensions :

Tolerance: ± 0.3 mm Unit: mm

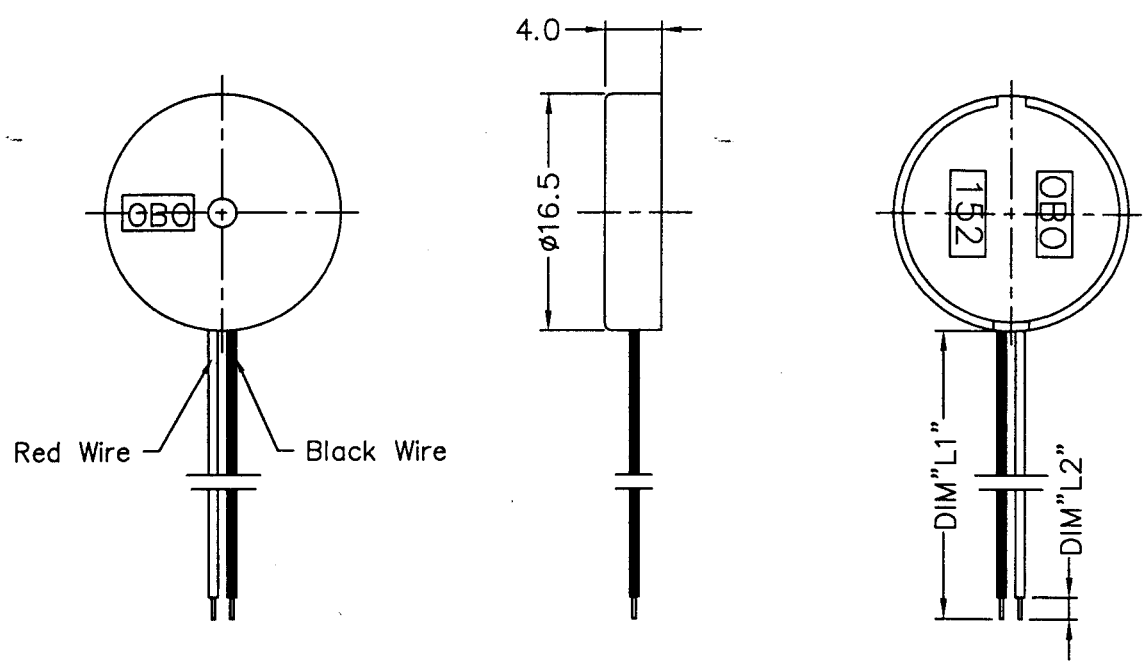

Customer	Lead Wire	DIM"L1"	DIM"L2"
Standard	UL 1571 32AWG	85 \pm 5	3 \pm 1

※1
3.1 Environment-related substances to be controlled

◎ Piezoelectric Ceramic Disc.

RoHs Annex :

Application of lead, mercury, cadmium and hexavalent chromium, which are exempted from the requirement of article 4(1).

* Lead in electronic ceramic parts.(e.g. piezoelectronic devices).

4. Soldering Condition :

Iron Tip Temperature	Soldering time
+ 380°C , Duration	3 seconds Max.

OBO Pro.2	SPECIFICATIONS	MODEL NO. OBO-152
	PART NAME Piezoelectric Buzzer	SHEET 4 OF 5

5. Packing Information :

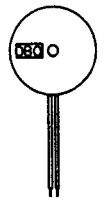

Buzzer

OBO PRO.2 INC.

MODEL NO.	
LOT NO.	
QUANTITY	
DATE	

100pcs / Label
(80*50*0.08mm)

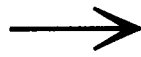

100pcs/ PE Bag
(220*155*0.05mm)

RoHS Tape ※1

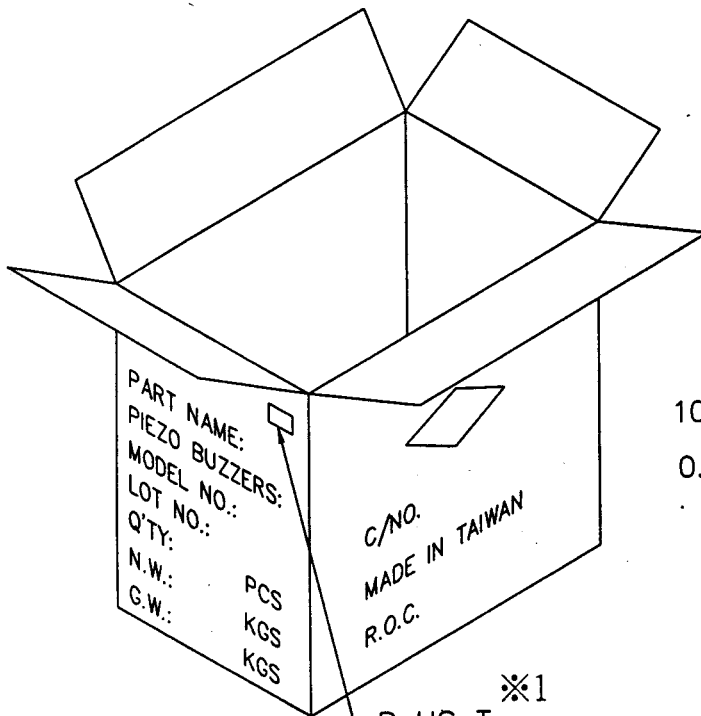

100 Bag(10,000pcs)/ Carton
0.96 呎(352*233*336mm)

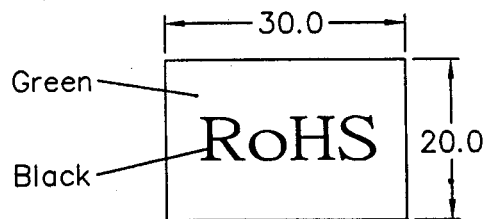

RoHS Tape
(30*20 mm) ※1

