	SPECIFICATIONS	MODEL NO. OBO-1206A-A2
	PART NAME Magnetic Transducer	SHEET 1 OF 5

ALTERNATION HISTORY

Marking	Date	ECN. NO.	REV.	Description	Page	PREPARE BY	APPROVE BY
※1	OCT,19,2004	0410005	G	Change Packing & Pb-free Soldering.	5	LULU	陳建合
※2	Sept,01,2005	0508010	H	Conformity RoHS Directive (2002/95/EC) Requests.	5	李維玲	Jan 9/12

REV.	DATE	PREPARED BY	CHECKED BY	APPROVED BY
H	Sept,12,2005	李維玲	李維玲	Jan 9/12

OBO Pro.2	SPECIFICATIONS	MODEL NO. OBO-1206A-A2
	PART NAME Magnetic Transducer	SHEET 2 OF 5

MODEL NO : OBO-1206A-A2

Features : Conformity RoHS Directive (2002/95/EC) Requests.

Wave solder and wash allowed. ※2

1. General Specifications :

Items	SPEC
※ Sound Pressure Level	85 dB min./10cm/DC 6V
Rated Voltage	DC 6V
Resonant Frequency	2400 Hz
※ Rated Current	50mA max./DC 6V
Coil Resistance	45 ± 6 Ω
Operating Voltage	DC 4 to 8 V
Housing Material	NORYL
Operating Temp. Range	-20°C to +70°C
Storage Temp Range	-30°C to +80°C
Weight	2.0 gms

※ Applying rated voltage/ Resonant Frequency , 1/2 duty Square wave

2. Recommended Driving Circuit:

Signal:

Resonant frequency, 1/2 duty cycle, square wave.
signal amplitude should be large enough to saturate the transistor which drives the buzzer.

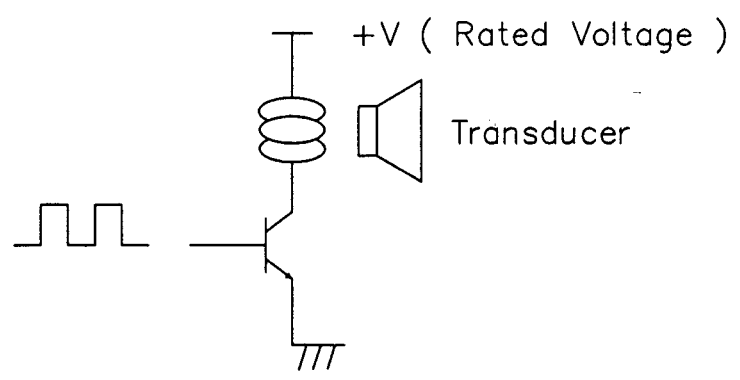

OBO Pro.2	SPECIFICATIONS	MODEL NO. OBO-1206A-A2
	PART NAME Magnetic Transducer	SHEET 3 OF 5

3. Mechanical Layout and Dimensions :

3.1 Dimensions

Tolerance: $\pm 0.5\text{mm}$ Unit: mm

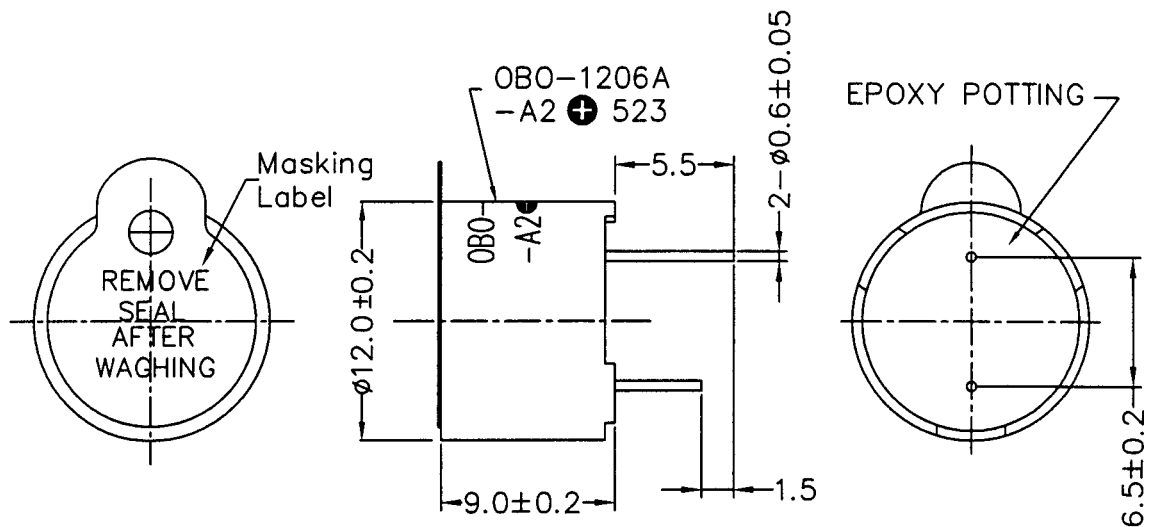

Wave Solder And Wash Not Allowed

3.2 Meaning of Stamp Mark

523 : Production Period

5 : Year 2005 (last 1 figures of the year)

23 : Week (01~55)

4. Soldering Condition : ※2

4.1 Wave Soldering

Peak temperature	Dipping time	Soldering
+ 230°C	5 seconds	1 time

4.2 Hand Soldering

Iron Tip Temperature	Soldering time
+ 350°C , Duration	3 seconds Max.

OBO Pro.2	SPECIFICATIONS	MODEL NO. OBO-1206A-A2
	PART NAME Magnetic Transducer	SHEET 4 OF 5

5. Packing Information : ※1

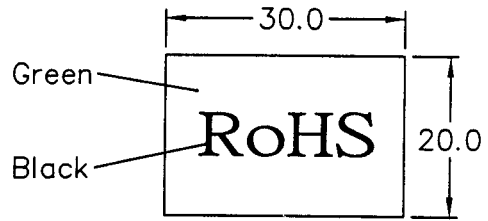

RoHS Tape
(30*20 mm) ※2

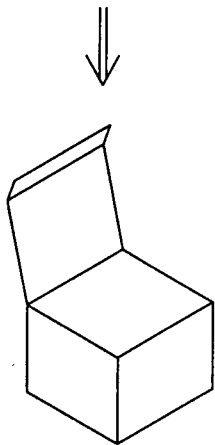
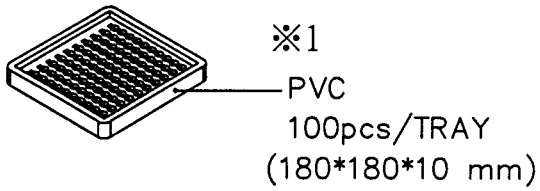

500pcs/5 TRAY

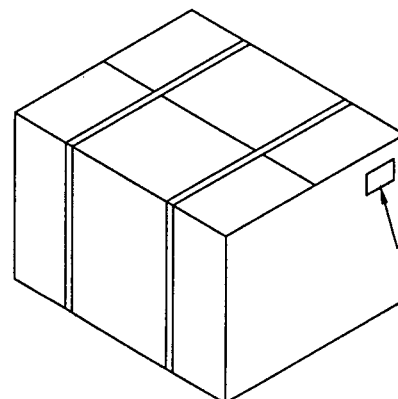
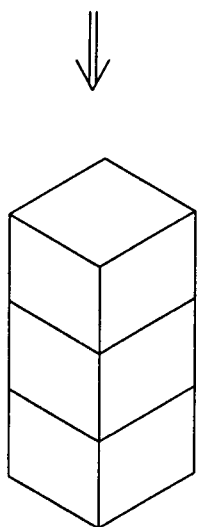
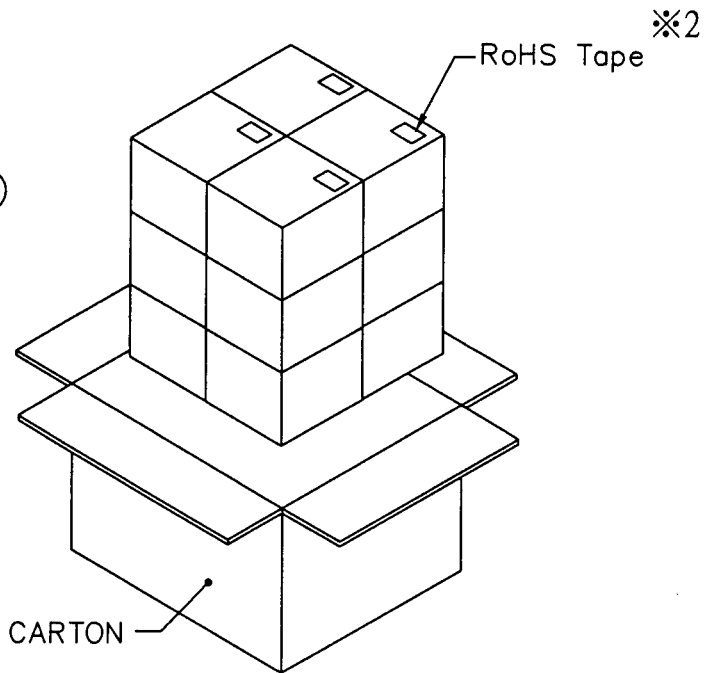

6000pcs/CARTON
(440X400X330mm)

